

COMTELCO

Technical Specification

BS2400XL12

2400-2500MHz, 12dBd / 14dBi Gain

BASE STATION ANTENNA

Reliable Performance: Rated at 250 watts, you can expect years of continuous service.

Construction: The radiating elements are collinear stacked and phased copper alloy tubes. They are encased in a coated fiberglass radome for total environmental protection.

Weatherproof: The fiberglass radome is ultraviolet inhibited. The heavy wall aluminum mounting sleeve is epoxy coated for weather protection. It features a complete drain system to provide excellent condensation dissipation.

Lightweight: These antennas are lightweight at less than 5 lbs. and are designed to easily withstand winds of over 125 MPH.

Simple Installation: Using the optional BSMNT2 mounting kit, installation takes only minutes.

Termination: This antenna is comes with an "N" female termination. Pigtail models with special connectors are available.

Downtilt Option: The XL12 comes in a 0° downtilt and -3° downtilt versions.



ELECTRICAL SPECIFICATIONS:

FREQUENCY:	2400-2500MHz
GAIN:	12dBd / 14dBi
VERTICAL BEAMWIDTH:	8°
BANDWIDTH:	100MHz @ <2:1
POWER RATING:	250 watts
IMPEDANCE:	50 ohms
DOWNTILT:	0° add -0 3° add -3

MECHANICAL SPECIFICATIONS:

ANTENNA LENGTH:	63"
WEIGHT:	5 lbs,
RADIATOR:	Copper alloy elements
RADOME:	White UV inhibited fiberglass
MOUNTING SLEEVE:	Heavy Wall epoxy coated aluminum
SLEEVE DIAMETER:	1.35"
WIND SURVIVAL:	125 MPH
TERMINATION:	"N" Female

Vertical Pattern

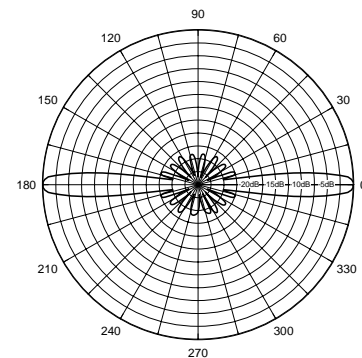

Vertical Pattern with Downtilt

